



Tamora Plus II

Dynamic Mattress Replacement System

UPRA367803-2

User Manual

Issue 8 – 06/02/2024
UPRA367803-2.UM-8

Contents

1. Introduction.....	4
2. Intended Use	4
2.1 Contraindications.....	4
3. About the Product.....	4
4. Symbols and Statements.....	6
5. Important Safety Information	7
6. Technical Specification	8
6.1 Power unit	8
6.2 Mattress	8
7. Installation and Set-Up.....	9
7.1 Setting up mattress.....	9
7.2 Setting up power unit.....	9
7.3 Cable management system	10
7.4 Connecting mattress to the power unit.....	10
8. Control Panel Operation Guide	11
8.1 Comfort level	11
8.2 Control panel lockout.....	12
8.3 Function mode switch.....	12
8.3.1 <i>Alternate</i>	12
8.3.2 <i>Static</i>	12
8.4 Alternate cycle time selection	12
8.5 Alarm mute	12
9. CPR Mode.....	13
10. Transport Mode	13
11. Alarms & Fault Findings.....	13
11.1 Low pressure alarm	13
11.2 Power failure alarm.....	14
11.3 Service (alternating failure alarm)	14
12. Troubleshooting.....	14
13. Cleaning and Decontamination	15
13.1 Basic cleaning information.....	15
13.2 Cover disinfection	15
13.3 Power unit disinfection.....	16
13.4 Cover laundering	16
14. Storage.....	16
15. Service and Maintenance	17
15.1 General	17
15.2 Fuse replacement.....	17
15.3 Air filter replacement.....	17
16. EMC Information.....	18

1. Introduction

This User Manual contains instructions for the installation, use and maintenance of the Ultimate Healthcare Tamora Plus II dynamic mattress replacement system. You must read and fully understand this manual before using the system.



- *Caution: Ultimate Healthcare shall not be liable for any damage or injury caused by failure to follow the proper instructions as described in this User Manual.*



- *Caution: Before using the dynamic mattress replacement system all staff must familiarise themselves thoroughly with the various parts and controls as detailed in this User Manual.*

Note: Ultimate Healthcare reserves the right to modify the information in this User Manual at any time. The information in this User Manual may vary slightly with respect to the basic design of the product.

2. Intended Use

The intended use of this product is to prevent and/or manage pressure ulcers while optimising patient comfort for patients up to 200kg / 31.5 stone.

2.1 Contraindications

- The mattress is not suitable for use on patients with unstable fractures.

3. About the Product

The Tamora Plus II dynamic mattress replacement system provides highly effective care and protection for patients at High to Very High Risk of pressure ulcer development and is a cost-effective solution for any healthcare environment.

Constructed of a single layer of alternating cells on an **integral foam base** the mattress is low enough to address key height safety issues whilst offering additional protection for the patient in the event of a power failure.

An **Auto-Lockout** feature prevents unintentional activation of the control panel ensuring that any setting changes are deliberate whilst the **Timed Static mode** automatically returns to Dynamic mode to safeguard patients against the risk of pressure damage.

Mattress Replacement

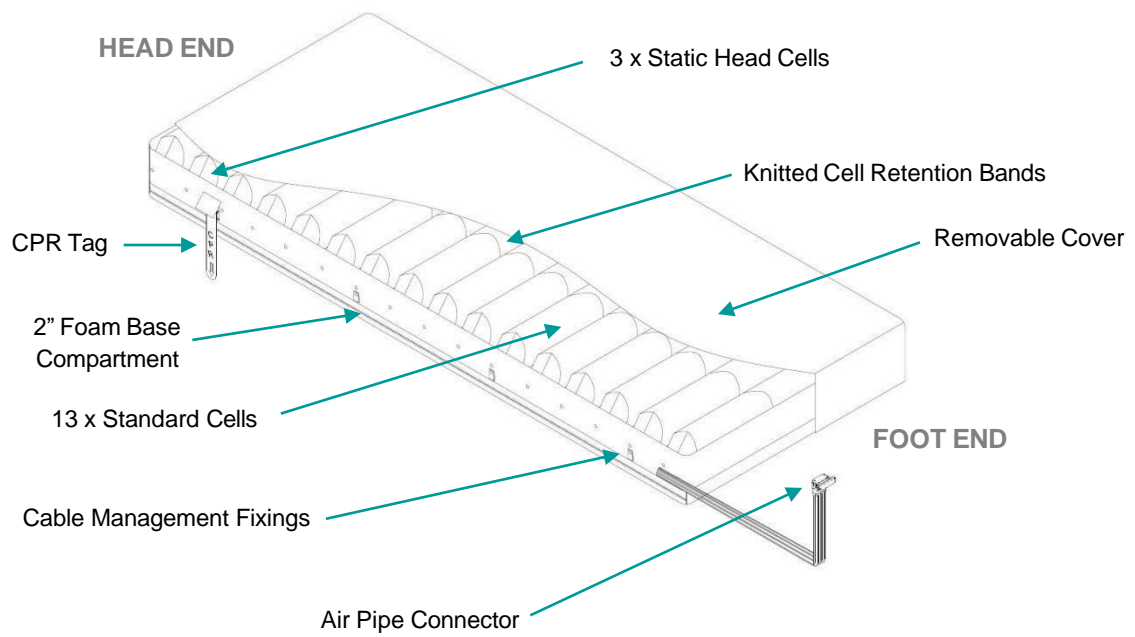

Power Unit

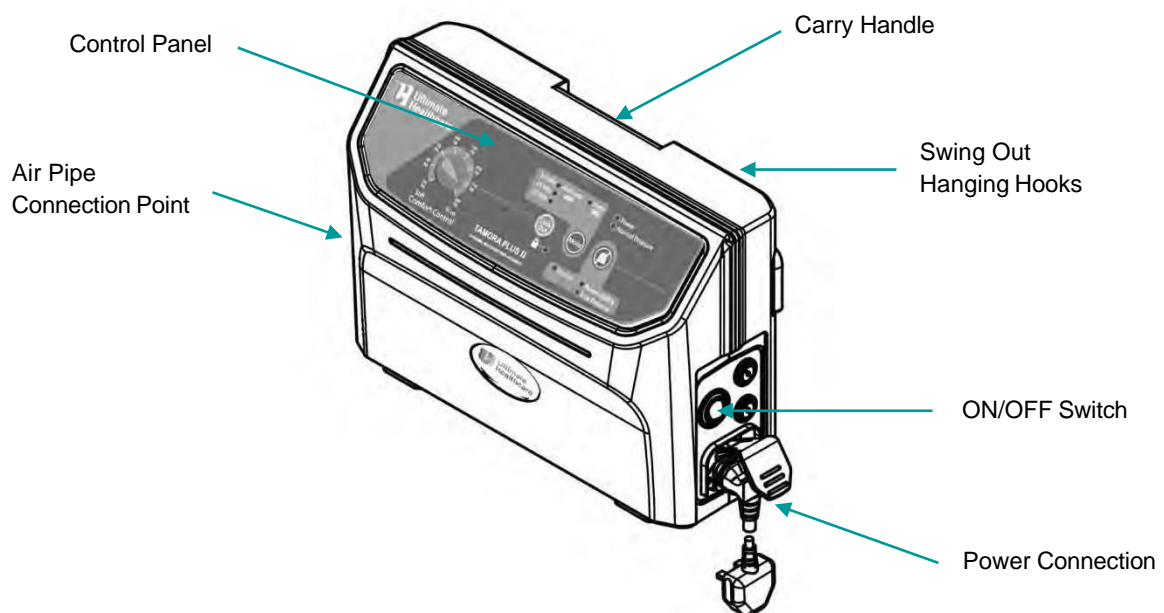

4. Symbols and Statements



Note: Indicates tips and advice for the correct use of this product.



Caution: Indicates correct operating or maintenance procedures in order to prevent damage to or destruction of the product or other property.



Warning: Indicates potential danger that requires correct procedures or practises in order to prevent personal injury.



Indicates this product is compliant to the degree of protection against electric shock for Class II type BF equipment.



Read instruction manual before use of the product

IP21

Water and dust protection classification.



Disposal of electrical and electronic equipment (WEEE): This product should be handed over to an applicable collection point for the recycling of electrical and electronic equipment.



CE certified.

5. Important Safety Information

Please read all instructions prior to using any Ultimate Healthcare supplied product. The Tamora Plus II dynamic mattress replacement system must be used in accordance with this User Manual.



The mattress must only be operated by personnel who have been properly trained or have suitable experience with products of this nature.



Ensure a clinical Risk Assessment is conducted, which should take account of the suitability of use of this product, patient's condition, any ancillary equipment in use and the surrounding environment. This should include assessing the use of side rails, head and footboards etc. Pressure settings should be advised or prescribed by a medical practitioner.



Only personnel trained or formally approved by Ultimate Healthcare in operation and maintenance of Ultimate Healthcare products may perform maintenance; modification or repair work on any Ultimate Healthcare supplied product.



Ensure the power cable is not trapped or twisted and is routed suitably to avoid crushing or entrapment when connected to the product.



Do not use your mattress system power unit in the presence of flammable gases. This excludes oxygen cylinders.



Avoid hazards caused by inappropriate handling of the power cable e.g. by kinking, shearing or other mechanical damages.



The power cable for this product must be unplugged from the mains power outlet socket and suitably stowed before moving, cleaning or maintenance activities.



Do not secure mattress straps to removable head or footboards or any fixed (non-moving) parts of a profiling bedframe.



Disconnect from mains (power supply) before cleaning the power unit.



When cleaning do not immerse the power unit in water.



Use only the cleaning and disinfectant agents recommended in this User Manual.



When connecting product after transportation or storage, inspect the power cable visually for any signs of damage. If evident, do not use product and contact Ultimate Healthcare or your local distributor for repair.



When storing, ensure the product is stored away from direct sunlight and extreme cold conditions.



Never block the air openings of this product or place it on a soft surface, such as a bed or couch, where their openings may be blocked. Keep the air opening free of lint, hair, and other similar particles. Air ventilation through the power unit is vital for correct and safe operation.



If this product is used for any activity other than detailed within this User Manual then personal risk to the end user or patient may occur. Ultimate Healthcare shall not be held liable/responsible for such an event.



Do not smoke, or allow the patient to smoke when using this product. Keep all possible ignition sources clear of this product

6. Technical Specification

6.1 Power unit

Dimensions:	130mm x 320mm x 230mm (D x W X H)
Weight:	3.5 kg
Alternating cycle time:	10 / 15 / 20 mins
Output pressure range:	30 to 70mmHg (+/-5)
Power supply:	AC 230V 50 Hz
Current:	0.12 A
Classification:	Class II, Type BF
Warranty:	2 years
Operation environment:	5°C to 40°C 15%RH ~ 93%RH (no condensation)
Storage environment:	-25°C~70°C ≤93%RH (no condensation)
Environment pressure:	70 kPa-101.3 kPa
Water & dust protection classification:	IP21

6.2 Mattress

Dimensions:	2000mm x 850mm x 180mm (L x W X H)
Weight:	9.1 kg
No of cells:	16
Cover material:	2 way stretch polyester with PU Coated
Bottom material:	PU coated polyester
Max user weight:	200 kg / 31.5 stone

7. Installation and Set-Up

7.1 Setting up mattress

For the comfort and safety of the patient do not put them onto the mattress until you are sure that the mattress is properly secured and the system indicates that it is fully inflated. The mattress is designed to completely replace any existing mattress which may be in use on a bed.

Remove any existing mattress and ensure that there are no protruding parts or sharp objects on the bed which could cause damage to the mattress. Lay the mattress on the bed patient surface ensuring that the air pipe connector is situated on the bottom left hand side of the bed foot end (as viewed from the foot of the bed). There are security straps fitted to the base cover of the mattress which should be fastened loosely to convenient points on the bedframe patient surface.

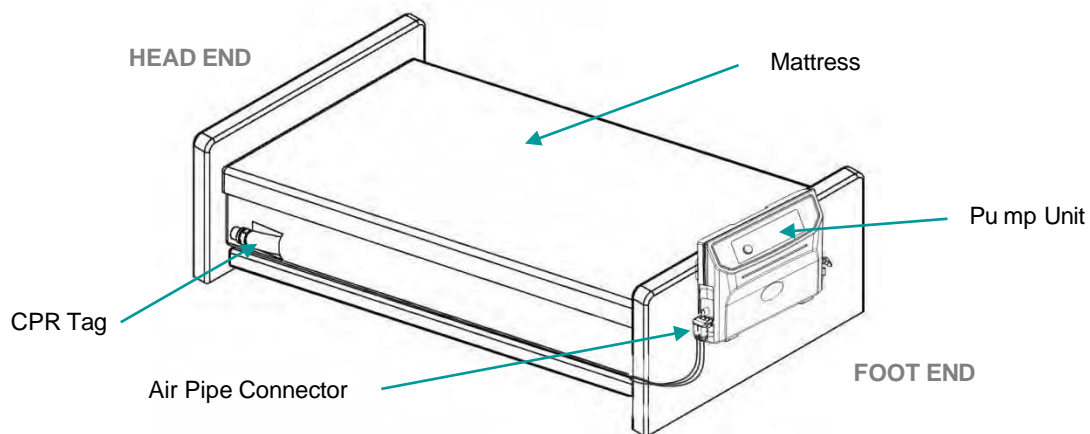

- *Caution: Ensure when fixing the mattress to the bed the security straps are only fitted to the moving parts of the mattress platform. Straps secured to the fixed parts of the mattress platform will damage the bed/mattress when operated.*

7.2 Setting up power unit

Whilst holding the power unit, unfold the hanging hooks on the rear of the power unit and hang it from the beds footboard. If required the power unit can be placed on the floor at the foot of the bed.



- *Caution: Ensure that the power cable is routed in such a manner so that it cannot be twisted, trapped, crushed or stressed.*

7.3 Cable management system

Cable management fixings are located on each side of the mattress underneath the flap of the cover. The mains power cable should be secured through the cable management fixing as follows:

- Locate each cable management fixing.
- If necessary, open the press studs.
- Run the mains power cable along the side of the mattress securing each fixing loop around the cable using the press studs.

7.4 Connecting mattress to the power unit

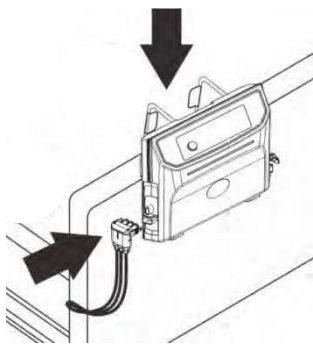

Remove the cover of the air pipe connector and connect the air pipe connector to the pump and then ensure that the air tubes are free from any kind of obstruction, and are not kinked.

Plug the power cable into a suitable electrical socket and switch 'ON' using mains power switch found at the side of the pump. All indicators on control panel will light up.

The power unit will start Inflation (inflation mode) and the **Normal Pressure** indicator will flash. Turn the comfort control to the maximum.

Once the mattress is fully inflated, you can then set to the appropriate setting suitable for the patient



- *Caution: The pump must only be connected to the mattress recommended by the manufacturer. Do not use it for any other purpose.*



- *Note: Ensure that the CPR tag is replaced in position over the CPR plugs.*

If the service light remains illuminated when the pump is first switched on the pump may need to be charged for up to 2 hours due to being stored.

8. Control Panel Operation Guide

The Control Panel of the power unit is used to make adjustments to the mattress and also indicates fault conditions/service requirements. These are either visual (indicator lights) or audible.

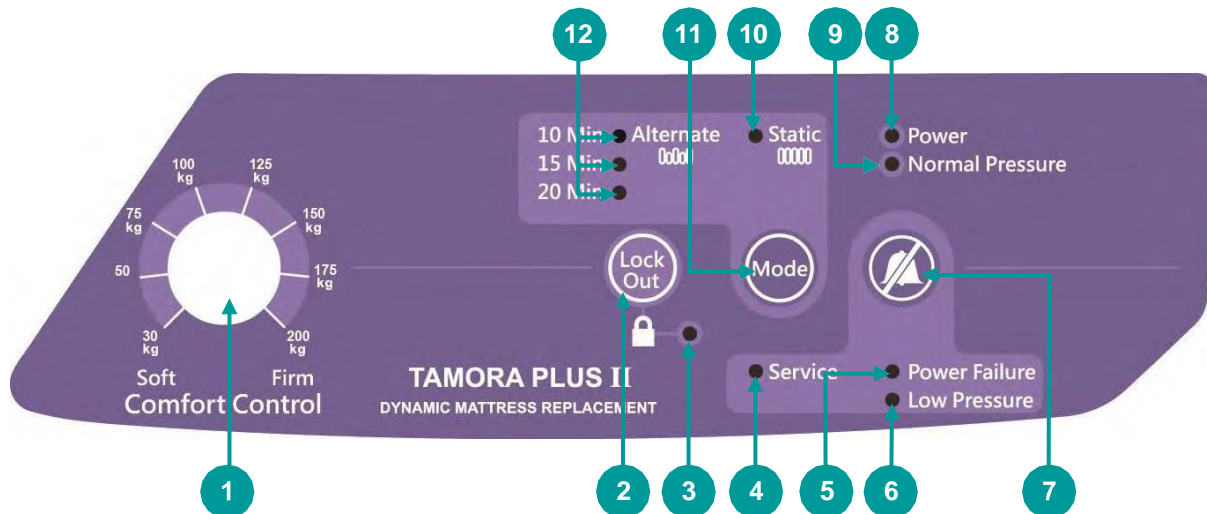

- | | | | |
|---|---------------------------------|----|---------------------------|
| 1 | Comfort Control Dial | 7 | Alarm Mute Button |
| 2 | Control Panel Lockout Button | 8 | Power Indicator |
| 3 | Control Panel Lockout Indicator | 9 | Normal Pressure Indicator |
| 4 | Service Indicator | 10 | Static Mode Indicator |
| 5 | Power Failure Alarm Indicator | 11 | Mode Selection Button |
| 6 | Low Pressure Alarm Indicator | 12 | Cycle Time Indicators |

8.1 Comfort level

The comfort level adjustment dial allows carers to adjust pressures within a safe pre-set range to provide patients with enhanced comfort or support whilst maintaining a very good level of protection and therapy. Qualified clinical advice must always be taken before adjusting mattress overlay pressures.

When the dial is turned towards **Firm**, the output pressure will increase to provide a higher pressure output and thus increased support.

When the dial is turned towards **Soft**, the output pressure will be decreased to provide a lower pressure output and thus increased comfort.

To check if the pressure is adequately supporting the patient, slide one hand between the mattress overlay and base mattress to feel under the patient's bottom. You should be able to slide the hand in-between and an acceptable range is approximately 25 to 40 mm (1" to 1-1/2") to ensure the patient is not bottoming out.

8.2 Control panel lockout



If the control panel is not used for a period of 30 seconds it will lock out and inhibit the use of the functions. Additionally, if you wish to lock out the control panel press the **Lock Out** button and all functions will be locked. This is to prevent the system being altered accidentally.

In order to unlock the control panel, simply press and hold the **Lock Out** button for 3 seconds, the control panel will now be active for use.

8.3 Function mode switch

8.3.1 Alternate



Alternating mode is the default mode for the system. Within this mode the mattress will operate in an alternating 1-in-2 cell cycle. The alternating cycle will continue at the selected cycle time until another mode is selected.

8.3.2 Static



Pressing the **Mode** button until the **Static** indicator illuminates puts the system into **Static** mode.

Within this mode the mattress will maintain a selected constant pressure. After 30 minutes the system will automatically revert back to **Alternating** mode.

8.4 Alternate cycle time selection



The alternating cycle times can be selected to provide an individualised care program for each patient.

Within **Alternating** mode the cycle time can be selected by pressing the **Mode** button. Selections can be made from 10-20 minutes at 5 minute intervals. The cycle time selection will be indicated by the relevant indicator light being illuminated.

8.5 Alarm mute



The **Alarm Mute** button temporarily resets the audible *Low Pressure/Power Failure/Service* alarms. Should the situation not be resolved and the fault condition continues the alarm will resume notifying carer.

9. CPR Mode



CPR (Cardio Pulmonary Resuscitation) can be performed using the red CPR valve which is situated at the head end on the left hand side of the mattress.

For rapid deflation release the CPR valve from the retaining ribbon and gently pull and rotate the dial of the CPR valve to 'click' into the OPEN position. At the same time, disconnect the air pipe connector from the power unit to speed up the air release.

If re-inflating the mattress, ensure the dial of the CPR attachment is rotated until it 'clicks' into the CLOSED position.

10. Transport Mode

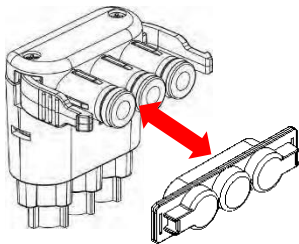

If the patient is being moved on the mattress, or there is a power cut, general pressure can be maintained in the system for an adequate period of time whilst disconnected from the mains.

Simply disconnect air pipe connector and place the connector cover over it. The air pressures in the mattress will now equalise, but maintain a degree of comfort. This will maintain the cells in their present state for up to 24 hours.

It is important to restore the Tamora Plus II dynamic replacement mattress as quickly as possible by reconnecting the supply tubes to the power unit.

11. Alarms & Fault Findings

The Tamora Plus II is equipped with audible and visual alarm indicators. These alert the user to the status of the available mains supply and any mattress defect.

11.1 Low pressure alarm

Upon detection of low pressure, an audible alarm will be heard and the **Low Pressure** indicator will illuminate. The audible alarm may be cancelled by pressing the **Alarm Mute** button. The **Low Pressure** indicator will continuously illuminate until the low pressure fault condition is resolved.

This condition could be caused, for example, by incorrect fitting of the air pipe connector, opening of the CPR valve or a leak in the mattress due to a cut or puncture.

11.2 Power failure alarm

If at any time the mains power should be removed from the power unit or the power cable is unplugged without turning the power unit OFF, an audible alarm will be heard and the **Power Failure** indicator will illuminate. The audible alarm may be cancelled by pressing the **Alarm Mute** button.



- *Note: When the power unit has not been used for more than 3 days, it might require 30 minutes operating time (or more) for the Alarm to function correctly.*

11.3 Service (alternating failure alarm)

Should your system develop a fault condition whilst in use, an audible alarm will be heard and the Service indicator will illuminate. The audible alarm may be cancelled by pressing the **Alarm Mute** button. Should the situation not be resolved and the fault condition continues the alarm will resume. Please contact Ultimate Healthcare or your local service provider.

12. Troubleshooting

PROBLEM	SOLUTION
No lights on power unit	<ul style="list-style-type: none"> • Check the power unit is connected to the mains power supply and that the mains switch is turned ON. • Check power unit for any blown fuses.
Low Pressure indicator is flashing and sounding	<ul style="list-style-type: none"> • Check to ensure that the CPR tag is securely fitted in place. • Check whether power was suddenly shut down. • Check that the connection between air tube and power unit is tightly secured. • Check that all tubing connections along the mattress are secured. • If all of above steps have been checked. Press “Alarm Mute” for system to be verified again.
Power Failure Alarm Indicator is flashing and sounding	<ul style="list-style-type: none"> • Check the power unit is connected to the mains power supply and that the mains switch is turned ON.
Patient is bottoming out (without alarm being triggered)	<ul style="list-style-type: none"> • Pressure setting might be inadequate for the patient, adjust comfort level to Firm and wait for a few minutes for a better comfort.
The power unit is operating but the mattress is not alternating	<ul style="list-style-type: none"> • Ensure that the mattress inflation process is complete. • Check that the ‘Alternate’ indicator on the control panel is illuminated. If not, press Function Select Button to switch to alternating mode.
Power unit is noisy	<ul style="list-style-type: none"> • Ensure that the power unit is resting against a solid surface.

If the problem persists, contact Ultimate Healthcare or your local service provider.

13 Cleaning and Decontamination

The following processes are recommended but should be adapted to comply with the local or national guidelines (Decontamination of Medical Devices) which may apply within the Healthcare Facility of use.

The Tamora Plus II Digital system should be routinely decontaminated between patients and at regular intervals while in use; as is good practice for all reusable medical devices.



- *Warning: Disconnect the power unit from the electricity supply before carrying out cleaning/decontamination procedures.*
- *Do not immerse or soak power unit.*

13.1 Basic cleaning information

Clean the mattress cover using single use wipes with a solution of neutral detergent and hand hot water. Rinse thoroughly with clean water and air dry the mattress.

When cleaning always visually check the mattress for cuts, cracks, pin holes or snags. Do NOT use a mattress with a damaged cover. If the inner core of the mattress is soiled you are advised to replace it.

13.2 Cover disinfection

If the cover is soiled or has been exposed to bodily fluids such as blood, it will require a more thorough cleaning procedure.

Use single use wipes with a 0.1% chlorine solution (1,000 ppm) and cold water to wipe the cover. Rinse thoroughly with clean water and damp dry the mattress using single use wipes. Ensure the cover and mattress are completely dried before refitting.



CAUTION: *Frequent or prolonged exposure to higher concentration disinfectant solutions may prematurely age the fabric cover of mattresses. Surfaces must be protected during use and rinsed and thoroughly dried after application of a disinfectant.*

13.3 Power unit disinfection

Wipe the pump unit with a damp cloth pre-soaked with a mild detergent and keep the pump away from dust. If other detergent is used, choose one that will have no chemical effects on the surface of the plastic case of the pump unit.



CAUTION: Do not immerse or soak the pump unit

13.4 Cover laundering

The mattress cover and air pipe cover can also be machine washed. Mattress covers and air pipe cover should be completely removed prior to laundering.

Where required mattress covers can be laundered in a pre-wash at 60°C for up to 15 minutes and in a main wash at 60°C for up to 15 minutes. This should be followed by a cold rinse and extraction. It is recommended that you check your approved local policy to determine the time/temperature ratio required to achieve thermal disinfection.

Mattress covers should be hung from a line or bar and drip dried in a clean indoor environment. Mattress covers may be tumble dried or air dried. They may be tumble dried on a low heat for up to 90 minutes. Drying temperature must not exceed 40°C.

Covers must be completely dried before refitting to the mattress.



CAUTION Exceeding the temperature can cause significant damage to the mattress cover.

14. Storage

The mattress should be loosely rolled lengthwise with the cover innermost, taking care not to strain the air pipe. It should then be placed in in a suitable protective cover with the power unit and stored in an area appropriate for electronic medical devices.

- To quickly extract air out from mattress for storage, pull the CPR tag to remove the CPR plugs and disconnect the air hose connector to release the air.
- Lay the mattress out flat.
- Roll from the head end towards the foot end.
- The foot end strap can then be stretched around the rolled mattress to prevent unrolling.
- The power cord could be wrapped around the power unit bumper or disconnected for storage.



CAUTION Do not fold, crease or stack mattresses

15. Service and Maintenance

It is recommended that this product be part of a routine preventative maintenance schedule with a planned service every 12 months regardless of product usage.

15.1 General

- (1) Check power cable and plug if there are abrasions or excessive wears.
- (2) Check mattress cover for signs of wear or damage. Ensure mattress cover and tubes are stubbed together correctly.
- (3) Check the air hoses for any kink or break. For replacement, please contact Ultimate Healthcare or your local distributor.

15.2 Fuse replacement

- (1) Disconnect the plug from mains power when a blown fuse is suspected.
- (2) Remove the cover of the fuse holder by means of a small screwdriver.
- (3) Insert a new fuse of the correct rating in, and replace the cover of the fuse holder back. The fuse should be rated as T1A.

15.3 Air filter replacement

- (1) Replace the air filter located at the handle on the back of the power unit.
- (2) The filter is reusable and can be washed gently with a mild detergent and water. Dry the filter before use.
- (3) Check and replace air filter regularly if environment is dirty.

16. EMC Information

Manufacturer's declaration-electromagnetic immunity			
The <u>device(s)</u> is intended for use in the electromagnetic environment (for home and professional healthcare) specified below. The customer or the user of the <u>device(s)</u> should assure that it is used in such an environment.			
Immunity test	IEC 60601 test level	Compliance level	Electromagnetic environment-guidance (for home and professional healthcare environment)
Electrostatic discharge(ESD) IEC 61000-4-2	Contact: ± 8 kV Air ± 2 kV, ± 4 kV, ± 8 kV, ± 15 kV	Contact: ± 8 kV Air ± 2 kV, ± 4 kV, ± 8 kV, ± 15 kV	Floors should be wood, concrete or ceramic tile. If floors are covered with synthetic material, the relative humidity should be at least 30%
Electrical fast transient/burst IEC 61000-4-4	± 2 kV for power supply lines ± 1 kV for input/output lines	± 2 kV for power supply lines $+ 1$ kV for input/output lines	Mains power quality should be that of a typical home and professional healthcare environment.
Surge IEC 61000-4-5	± 0.5 kV, ± 1 kV line(s) to line(s) ± 0.5 kV, ± 1 kV, ± 2 kV line(s) to earth	± 0.5 kV, ± 1 kV line(s) to line(s) Not applicable	Mains power quality should be that of a typical home and professional healthcare environment.
Voltage Dips, short interruptions and voltage variations on power supply input lines IEC 61000-4-11	Voltage dips: 0 % U_T ; 0,5 cycle 0 % U_T ; 1 cycle 70 % U_T ; 25/30 cycles Voltage interruptions: 0 % U_T ; 250/300 cycle	Voltage dips: 0 % U_T ; 0,5 cycle 0 % U_T ; 1 cycle 70 % U_T ; 25 cycles Voltage interruptions: 0 % U_T ; 250 cycle	Mains power quality should be that of a typical home and professional healthcare environment. If the user of the <u>device(s)</u> requires continued operation during power mains interruptions, it is recommended that the <u>device(s)</u> be powered from an uninterruptible power supply or a battery.
Power frequency(50, 60 Hz) magnetic field IEC 61000-4-8	30 A/m 50 Hz or 60 Hz	30 A/m 50 Hz	The <u>device(s)</u> power frequency magnetic fields should be at levels characteristic of a typical location in a typical home and professional healthcare environment.
NOTE UT is the a.c. mains voltage prior to application of the test level.			

Recommended separation distance between portable and mobile RF communications equipment and the device(s)

The device(s) is intended for use in an electromagnetic environment (for home and professional healthcare) in which radiated RF disturbances are controlled. The customer or the user of the device(s) can help prevent electromagnetic interference by maintaining a minimum distance between portable and mobile RF communications equipment (transmitters) and the device(s) as recommended below, according to the maximum output power of the communications equipment.

Rated maximum output power of transmitter W	Separation distance according to frequency of transmitter m		
	150 kHz to 80 MHz $d = 1,2\sqrt{P}$	80 MHz to 800 MHz $d = 1,2\sqrt{P}$	800 MHz to 2,7 GHz $d = 2,3\sqrt{P}$
0,01	0,12	0,12	0,23
0,1	0,38	0,38	0,73
1	1,2	1,2	2,3
10	3,8	3,8	7,3
100	12	12	23

For transmitters rated at a maximum output power not listed above, the recommended separation distance d in meters (m) can be estimated using the equation applicable to the frequency of the transmitter, where p is the maximum output power rating of the transmitter in watts (W) according to the transmitter manufacturer.

NOTE1 At 80 MHz and 800 MHz, the separation distance for the higher frequency range applies.

NOTE2 These guidelines may not apply in all situations. Electromagnetic propagation is affected by absorption and reflection from structures, objects and people.

Manufacturer's declaration-electromagnetic immunity

Test specifications for ENCLOSURE PORT IMMUNITY to RF wireless communications equipment

The device(s) is intended for use in the electromagnetic environment (for home and professional healthcare) specified below. The customer or the user of the device(s) should assure that it is used in such an environment.

Test frequency (MHz)	Band ^{a)} (MHz)	Service ^{a)}	Modulation ^{b)}	Maximum power (W)	Distance (m)	IMMUNITY TEST LEVEL (V/m)	Compliance LEVEL (V/m) (for home and professional healthcare)
385	380 – 390	TETRA 400	Pulse modulation b) 18 Hz	1,8	0,3	27	27
450	430 – 470	GMRS 460, FRS 460	FM c) ±5 kHz deviation 1 kHz sine	2	0,3	28	28
710	704 – 787	LTE Band 13, 17	Pulse modulation b) 217 Hz	0,2	0,3	9	9
745							
780							
810	800 – 960	GSM 800/900, TETRA 800, iDEN 820, CDMA 850, LTE Band 5	Pulse modulation b) 18 Hz	2	0,3	28	28
870							
930							
1 720	1 700 – 1 990	GSM 1800; CDMA 1900; GSM 1900; DECT; LTE Band 1, 3,	Pulse modulation b) 217 Hz	2	0,3	28	28
1 845							
1 970							
2 450	2 400 – 2 570	Bluetooth, WLAN, 802.11 b/g/n, RFID 2450, LTE Band 7	Pulse modulation b) 217 Hz	2	0,3	28	28
5 240	5 100 – 5 800	WLAN 802.11 a/n	Pulse modulation b) 217 Hz	0,2	0,3	9	9
5 500							
5 785							

NOTE If necessary to achieve the IMMUNITY TEST LEVEL, the distance between the transmitting antenna and the ME EQUIPMENT or ME SYSTEM may be reduced to 1 m. The 1 m test distance is permitted by IEC 61000-4-3.

- a) For some services, only the uplink frequencies are included.
- b) The carrier shall be modulated using a 50 % duty cycle square wave signal.
- c) As an alternative to FM modulation, 50 % pulse modulation at 18 Hz may be used because while it does not represent actual modulation, it would be worst case.

Notes:

Notes:

Ultimate Healthcare Ltd

Calmore Industrial Estate, Nutwood Way, Totton

Southampton, Hampshire, SO40 3WW

Tel: 0333 321 8996

Email: enquiries@ultimatehealthcare.co.uk

www.ultimatehealthcare.co.uk

